



TREEMASTER
S RANGE



TREEMASTER
A Cut Above

 **RANSOME**
ATTACHMENTS

EXAK-1
One

MANUFACTURING CAPABILITY COMES ATTACHED



Exac-One has been dedicated to the world of excavator attachments since 2002 and today is one of the UK's leading suppliers, offering an extensive product range. It leads the way in design innovation to produce attachments which improve productivity, efficiency and safety.

		S210	S310
Excavator weight	Tons	3-9	6-18
Shear weight	lbs	500	792
Accumulator / Timber Support	lbs	120	198
Minimum grip diameter	Inches	2	2
Maximum cut diameter	Inches	8.5	12.5
Oil flow	gal/min	7.7 – 19.8	227-545
Oil Pressure	psi	2610 – 3625	2610 – 3625
Accumulator grab/ timber support		Optional	Optional
Diverter valve kit		Optional	Optional

	S210	S310
A	43	54
B	32	42
C	25	31
D	19	27
E	20	25
F	10	12
G	14	17
H	38	44

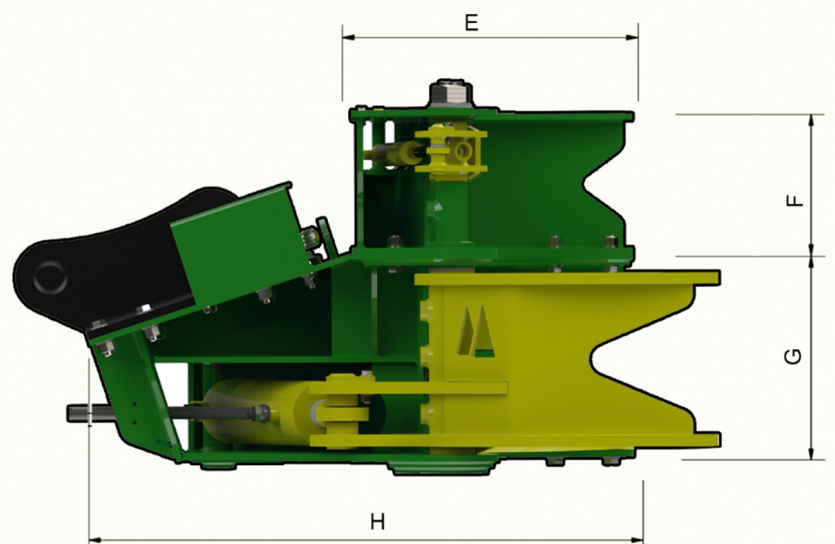
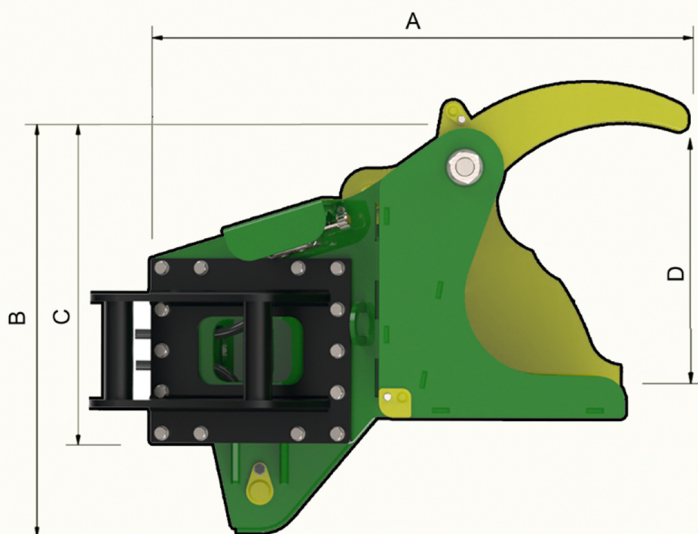



TREEMASTER

AT A GLANCE

- 'Clean Cut' blade design.
- Strenx 700 body.
- Removable Abramax 520CR blade.
- Accumulator grab option.
- 180 degree tilt option.
- Timber support.
- Simple and strong.
- Designed and manufactured in England.



TREEMASTER

A CUT ABOVE

TREEMASTER

Shear Perfection

Whole Tree Felling

Boudary Restoration

Tree Pruning

Woodland Maintenance

Thinning & Coppicing

Waste Timber Processing



NJ based Exac-One distributor

For more information:

1-888-280-1710

sales@ransomeattach.com

ransomeattach.com

**Product demo videos on our
YouTube channel**